

⊕ 주요용도(Application)

공작기계, 산업용로봇, 자동화설비 등의 전선이나 유·공압 Hose를 보호하면서 자유로이 운반하기 위한 보호관입니다.

⊕ 특징(Features)

- 내부잠김방식을 채택하여 연속 감김방식으로 제작하여 이탈을 최대한 방지하고 유연합니다.
- 아연도 강판을 사용하여 외관이 미려하고 전선이나 유·공압 Hose를 외부로부터 완벽하게 보호해 줍니다.
- Spring steel은 Stainless 강판을 사용하여 유연하고 산화되지 않습니다.
- 규격은 표준품 외에 어떠한 규격도 생산·공급할 수 있습니다.
- 재질을 비철금속(Stainless steel, Bronze, Aluminum)으로도 공급합니다.



CABLE DUCT (전선 유 · 공압 호스보호 Cover)

⊕ 왕복시험

1,000만회의 실험에서도 손상이 없는 것으로 시험되었습니다.

⊕ FLEX DUCT 계산식

$$L = \frac{\text{최대스트로크}}{2} + 5R \quad (R = \text{굽힘반경})$$

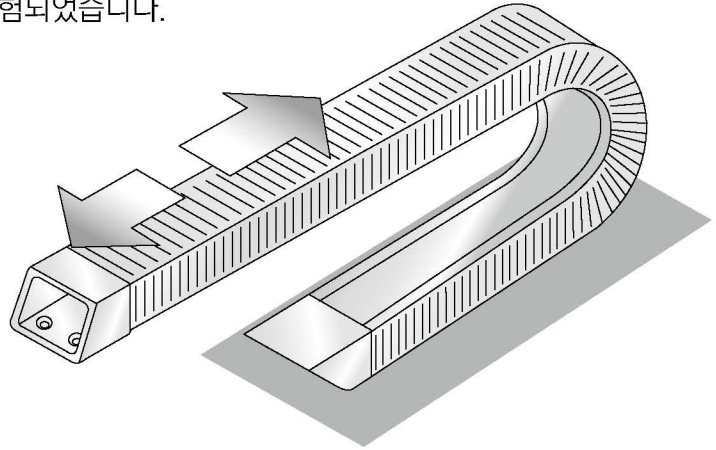

⊕ 속도 50m/min

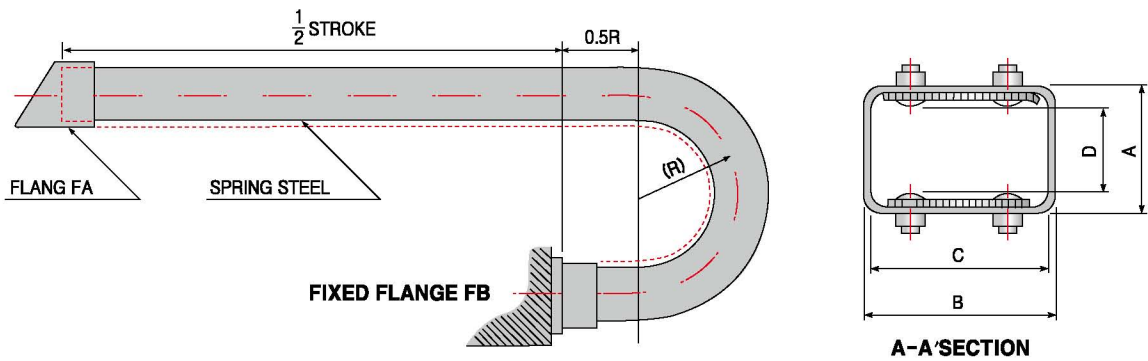

⊕ FLEX DUCT 규격

형식	품번	외경 A X B m/m	내경 D X C m/m	굽힘반경(R) ± 10%/m/m	무게 kg/m	비고
OK-1	S1001	25 X 60	20 X 55	60	1.1	
1K	S1010	30 X 50	23 X 43	60	1.5	
1K-1	S1011	50 X 50	45 X 45	120	1.8	
2K	S1020	45 X 80	41 X 75	110	2.9	
2K-1	S1021	50 X 95	45 X 90	125	3.7	
2K-2	S1022	60 X 85	55 X 80	130	3.9	
3K	S1030	60 X 110	55 X 105	130	4.5	
4K	S1040	80 X 115	74 X 109	170	4.9	
4K-1	S1041	80 X 170	72 X 162	170	5.6	
5K	S1050	90 X 140	85 X 135	180	6.8	
5K-1	S1051	95 X 170	88 X 162	210	7.2	
6K	S1060	110 X 175	104 X 170	250	7.6	
7K	S1070	100 X 200	92 X 192	250	7.8	
8K	S1080	110 X 220	102 X 212	250	8.1	

FLANGE FA.

FLANGE FA 도면

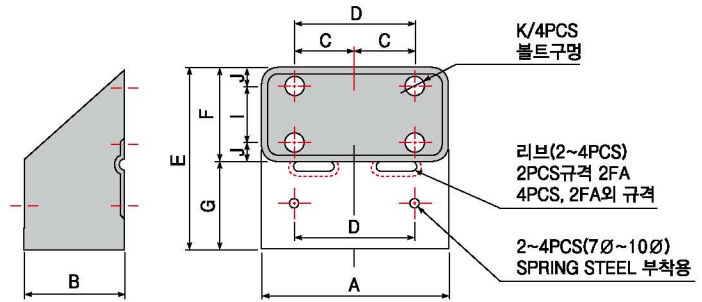
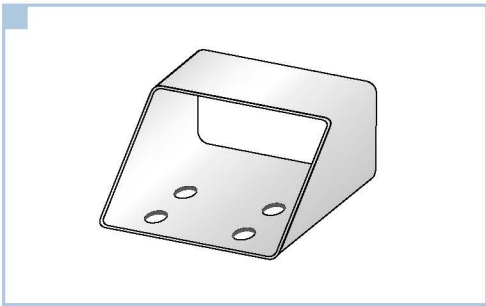

FLANGE FA 규격

단위 mm

규격	A	B	C	D	E	F	G	I	J	K	비고
OK-1	67	32	12.5	25	70	35	35	-	15	7Ø	
1K	57	37	10	20	70	35	35	-	15	7Ø	
1K-1	57	57	10	22	60	30	30	-	15	7Ø	
2K	92	52	22.2	45	104	52	52	-	10	10Ø	
2K-1	102	57	25	50	104	52	52	-	10	10Ø	
2K-2	92	67	22.5	45	120	60	60	40	10	10Ø	
3K	122	67	35	70	120	60	60	40	10	10Ø	
4K	122	87	35	70	120	60	60	40	10	10Ø	
4K-1	179	89	50	100	140	70	70	40	10	10Ø	
5K	149	99	40	80	140	70	70	40	10	10Ø	
5K-1	179	104	50	100	140	70	70	40	10	10Ø	
6K	184	119	65	130	160	80	80	40	20	10Ø	
7K	212	112	65	130	160	80	80	40	20	10Ø	
8K	232	122	65	130	160	80	80	40	20	10Ø	

FLANGE의 사용예

TYPE 1
FA/FA

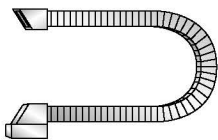

TYPE 2
FA/FA

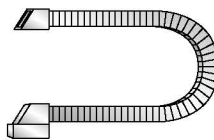

TYPE 3
FB/FA

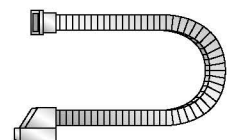

TYPE 4
FA/FA

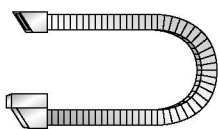

TYPE 5
FA/FA

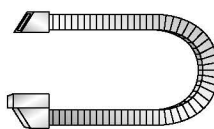

TYPE 6
FB/FA

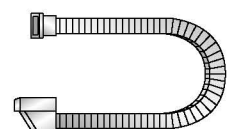

TYPE 7
FB/FA

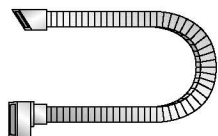

TYPE 8
FB/FA

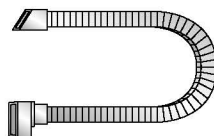

TYPE 9
FB/FB

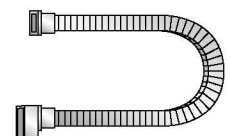

FLANGE FB 도면

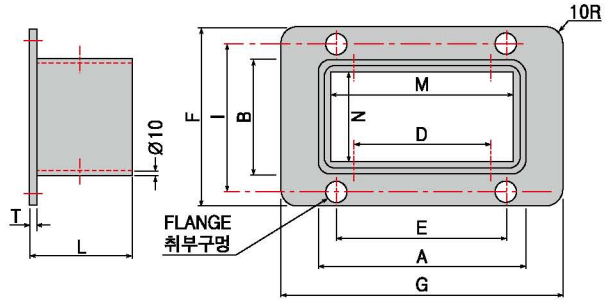
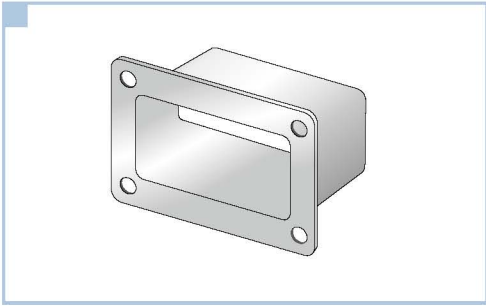

FLANGE FB 규격

단위 mm

규격	A	B	E	I	F	G	K	M	N	L	T	비고
OK-1	67	32	72	42	55	85	7Ø	57	22	30	2.0	
1K	57	37	50	53	67	87	7Ø	47	27	30	2.0	
1K-1	57	57	70	70	85	85	7Ø	47	47	30	2.0	
2K	92	52	80	70	90	100	10Ø	81	41	45	2.0	
2K-1	102	57	90	76	96	131	10Ø	91	46	52	2.0	
2K-2	92	67	80	85	105	121	10Ø	81	56	60	2.0	
3K	122	67	110	85	105	150	10Ø	110	55	60	3.0	
4K	122	87	110	105	125	150	10Ø	110	75	60	3.0	
4K-1	179	89	165	110	130	215	10Ø	165	75	70	3.0	
5K	149	99	130	120	140	175	10Ø	135	85	70	3.0	
5K-1	179	104	165	125	145	215	10Ø	165	90	70	3.0	
6K	184	119	170	140	160	220	10Ø	170	105	80	3.0	
7K	212	112	197	130	152	247	10Ø	197	97	80	3.0	
8K	232	112	217	140	162	267	10Ø	217	107	80	3.0	

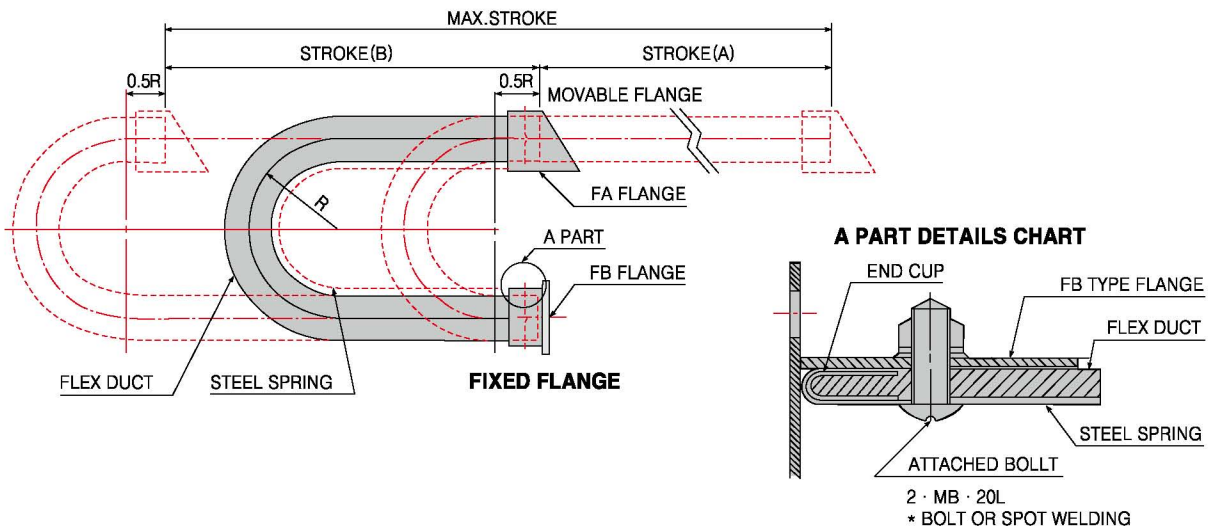

FLANGE FB.